

Coolant Control Valve

The coolant control valve is a continuous-duty, normally closed valve with a maximum flow rate of 0.5 L/s. Originally designed to control the flow of coolant in an off-highway SCR system, this valve can be used for other applications and is available in both submersible and non-submersible configurations.

Features & Benefits

- + Continuous duty, normally closed valve
- + Submersible and non-submersible configurations
- + IP65 and IP67 rated options

Applications

- + Coolant control
- + Flow control
- + Water control

Technical Data (custom configurations available)

- + Operating range: 12-24 Vdc
- + Maximum flow rate: 0.5 L/s
- + Coolant temperature range: -40°C to 110°C
(-40°F to 230°F)
- + Current draw: 2.5 A max
- + Response time: < 1 sec
- + Maximum pressure: 500 kPa

All TLX components are customized to fit system requirements, meaning technical specifications are unique to each customer and design. Examples given are for illustration purposes only.

Dimensional Drawings (dimensions in millimeters [inches])

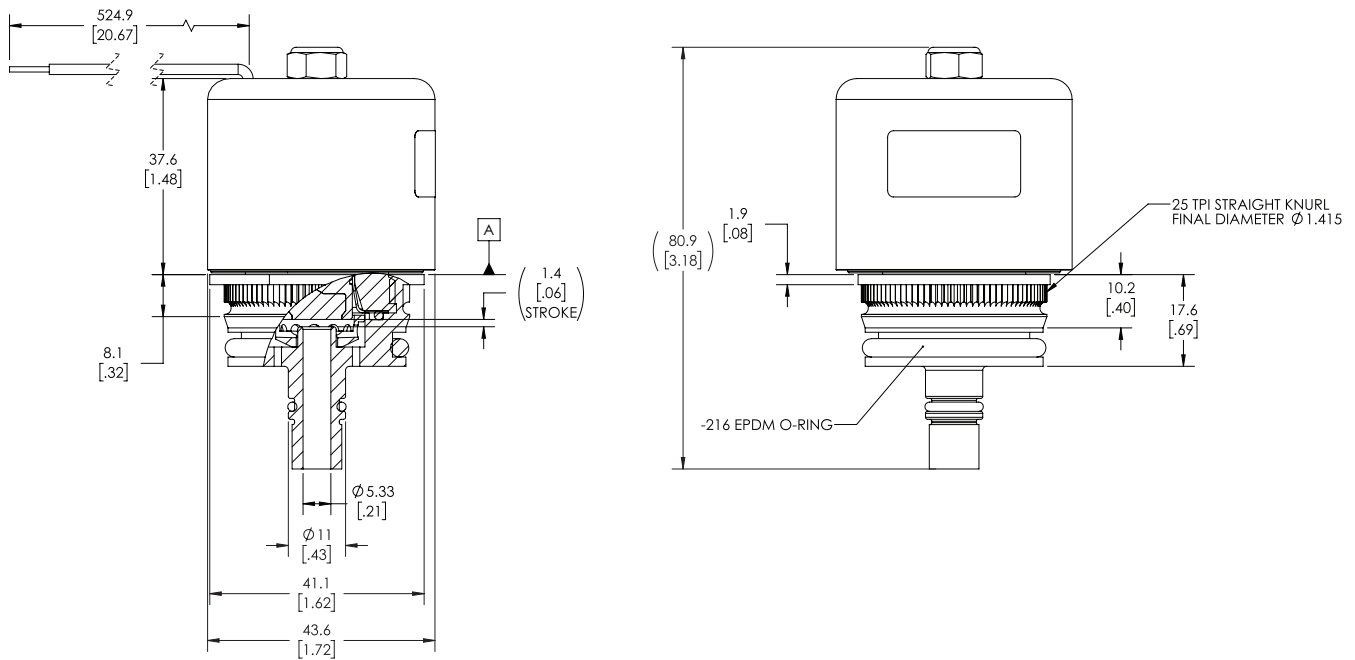

Legal Disclaimer Notice

ALL PRODUCT, PRODUCT SPECIFICATIONS, AND DATA ARE SUBJECT TO CHANGE WITHOUT NOTICE TO IMPROVE RELIABILITY, FUNCTION, DESIGN OR OTHERWISE.

TLX Technologies, LLC makes no warranty, representation or guarantee regarding the suitability of the products for any particular purpose or the continuing production of any product. To the maximum extent permitted by applicable law, TLX Technologies disclaims (i) any and all liability arising out of the application or use of any product, (ii) any and all liability, including without limitation special, consequential or incidental damages, and (iii) any and all implied warranties, including warranties of fitness for particular purpose, non-infringement and merchantability.

Statements regarding the suitability of products for certain types of applications are based on TLX Technologies' knowledge of typical requirements that are often placed on TLX Technologies' products in generic applications. Such statements are not binding statements about the suitability of products for a particular application. It is the customer's responsibility to validate that a particular product with the properties described in the product specification is suitable for use in a particular application. Parameters provided in data sheets and/or specifications may vary in different applications, and performance may vary over time. All operating parameters, including typical parameters, must be validated for each customer application by the customer's technical experts. Product specifications do not expand or otherwise modify TLX Technologies' terms and conditions of purchase, including but not limited to the warranty expressed therein.

No license, express or implied, by estoppel or otherwise, to any intellectual property rights is granted by this document or by any conduct of TLX Technologies. Product names and markings noted herein may be trademarks of their respective owners.