

## Digital High-Speed Control Valve



The digital high-speed control valve was designed for high-pressure gas vessels and worked independently of pressures or flow forces. The valve used residual magnetism and a proprietary control circuit to latch the spool without the application of constant current. Control circuitry was available to verify the speed and consistency of spool shift. A fail-safe sequence or position was pre-programmable in the event that control power was lost, and a minimum flow threshold was preset through parallel flow passages within the valve structure.

### Features & Benefits

- + Fast response time
- + Control flexibility
- + Matched electronics
- + Low power consumption
- + Fail-safe control

### Applications

- + High-speed pressure control
- + Vehicle airbags

### Technical Data (custom configurations available)

- + Supply voltage: 8 to 16 Vdc
- + Stroke: Up to .762 mm (.03 in.)
- + Open flow area: Up to 484 mm<sup>2</sup> (.75 in.<sup>2</sup>)
- + Response time: 1.5 to 3.0 ms
- + Current: 7.5 A
- + Solenoid force generated: Up to 450 N (101 lb)

*All TLX components are customized to fit system requirements, meaning technical specifications are unique to each customer and design. Examples given are for illustration purposes only.*

**Dimensional Drawings (dimensions in millimeters [inches])**

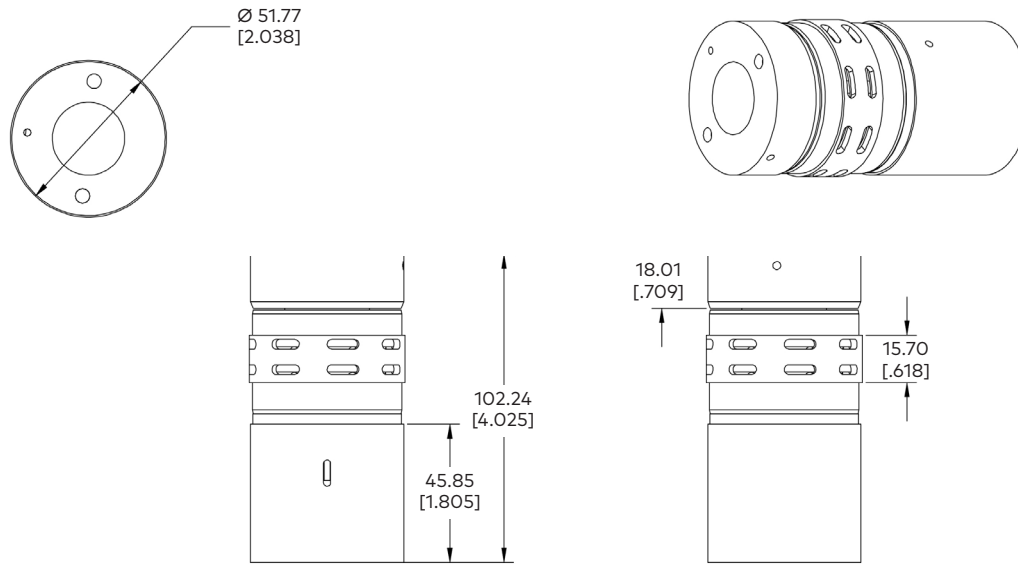

**Legal Disclaimer Notice**

ALL PRODUCT, PRODUCT SPECIFICATIONS, AND DATA ARE SUBJECT TO CHANGE WITHOUT NOTICE TO IMPROVE RELIABILITY, FUNCTION, DESIGN OR OTHERWISE.

TLX Technologies, LLC makes no warranty, representation or guarantee regarding the suitability of the products for any particular purpose or the continuing production of any product. To the maximum extent permitted by applicable law, TLX Technologies disclaims (i) any and all liability arising out of the application or use of any product, (ii) any and all liability, including without limitation special, consequential or incidental damages, and (iii) any and all implied warranties, including warranties of fitness for particular purpose, non-infringement and merchantability.

Statements regarding the suitability of products for certain types of applications are based on TLX Technologies' knowledge of typical requirements that are often placed on TLX Technologies' products in generic applications. Such statements are not binding statements about the suitability of products for a particular application. It is the customer's responsibility to validate that a particular product with the properties described in the product specification is suitable for use in a particular application. Parameters provided in data sheets and/or specifications may vary in different applications, and performance may vary over time. All operating parameters, including typical parameters, must be validated for each customer application by the customer's technical experts. Product specifications do not expand or otherwise modify TLX Technologies' terms and conditions of purchase, including but not limited to the warranty expressed therein.

No license, express or implied, by estoppel or otherwise, to any intellectual property rights is granted by this document or by any conduct of TLX Technologies. Product names and markings noted herein may be trademarks of their respective owners.