

LATCHING TECHNOLOGY Capable of holding in position without the constant application of electrical current. Latching technology is well suited for battery operated applications.

HIGH-SPEED TECHNOLOGY For applications requiring extremely accurate and high speed control of fluids, position or pressure. TLX's technology allows for response times in as little as 200 microseconds.

PROPORTIONAL TECHNOLOGY For applications requiring accurate and repeatable control, low hysteresis, and a flat force vs. stroke curve. TLX's technology allows for a smaller package size for the same force requirement.

HIGH TEMPERATURE TECHNOLOGY For applications requiring consistent performance under extremely high operating temperatures. TLX's high temperature technology offers proven operation in ambient temperatures exceeding 500°F (260°C).

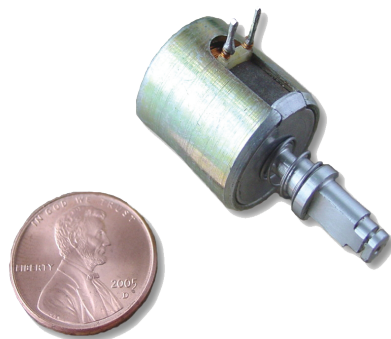

Features & Benefits

- Compact design
- High latching forces
- Fast response
- Low power consumption
- Can be designed for specific load holding capability
- Can be designed to configure with customer power requirements

Description

This latching solenoid example is manually actuated from the de-latched to the latched position. Once in the latched position, a permanent magnet field is used to hold the solenoid in the latched state. The solenoid is returned to the de-latched position by applying a short voltage or current pulse that cancels the permanent magnet field. Strokes and forces are flexible depending upon solenoid size.

Typical Applications

- Air Bag Vents
- Battery Disconnects
- Trunk Release Systems
- Vehicle Door Locks
- Battery Operated Locks
- Vending Equipment
- Medical Supply Cabinets

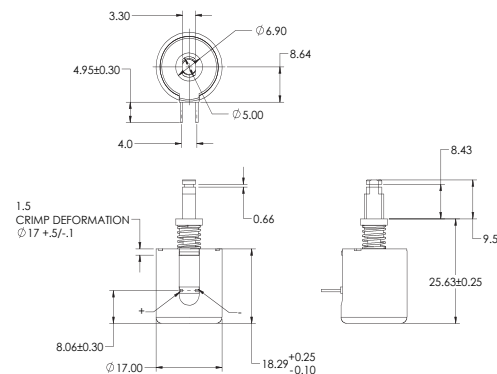

Typical Specifications (Custom configurations available)

Stroke (can be designed to specification)	2.5 mm (.098 in)
Holding Force	>28 N (>6.29 lbs)
Supply Voltage	6-16 Vdc
Response Time	>3 ms
Coil Resistance at 20°C	16.5 Ω ± 10%
Spring Load	5 N (1.124 lbs)
Current	.7 amps

View more information and read additional case studies on our website at www.tlxtech.com.

