

Proportional Canister Purge Valve

The proportional canister purge valve is a compact, fully encapsulated, pulse-width-modulated solenoid valve for a vehicle's EVAP system. It proportionally regulates the flow of fuel vapor from a vehicle's charcoal canister to the intake manifold to be burned off during combustion. The flow rate can be customized between 22 SLPM and 32 SLPM at a 70% duty cycle, with flow measured at a 50 kPa pressure differential.

Typical High Flow Valve

Flow vs Duty at 32 Hz, 12VDC, 50kPa Vacuum

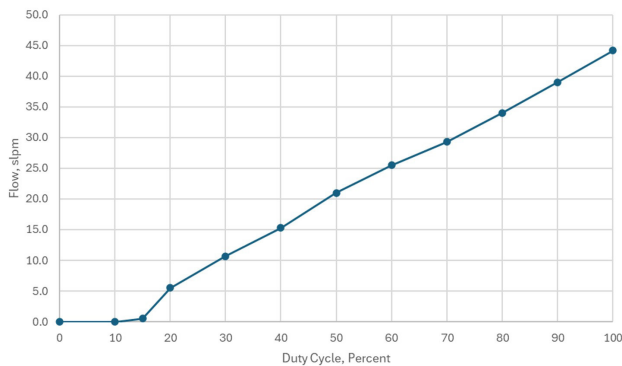

Typical Low Flow Valve

Flow vs Duty at 32 Hz, 12VDC, 50kPa Vacuum

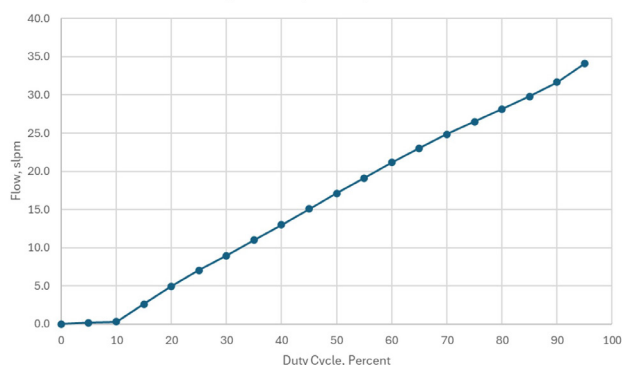

All TLX components are customized to fit system requirements, meaning technical specifications are unique to each customer and design. Examples given are for illustration purposes only.

Features & Benefits

- + Two-port, normally closed valve
- + Pulse-width-modulated proportional flow control
- + Compact, fully encapsulated design
- + Low internal leakage
- + Can be optimized for specific pressure and vacuum ranges
- + Hardware-free mounting
- + Customizable flow rate
- + Can be configured to integrate with the customer's electronic drivers

Technical Data (custom configurations available)

- + Flow rate range: 9-31 SLPM @ 50 kPa
- + Inductance: 25 ± 5 mH
- + Coil resistance at 20°C: 18.6 ± 1.8 Ω
- + Supply voltage: 12 Vdc @ 32 Hz PWM
- + Response time: < 8 ms
- + Operating temperature range: -40°C to 120°C (-40°F to 248°F)
- + Vibration: 20 G

Dimensional Drawings (dimensions in millimeters [inches])

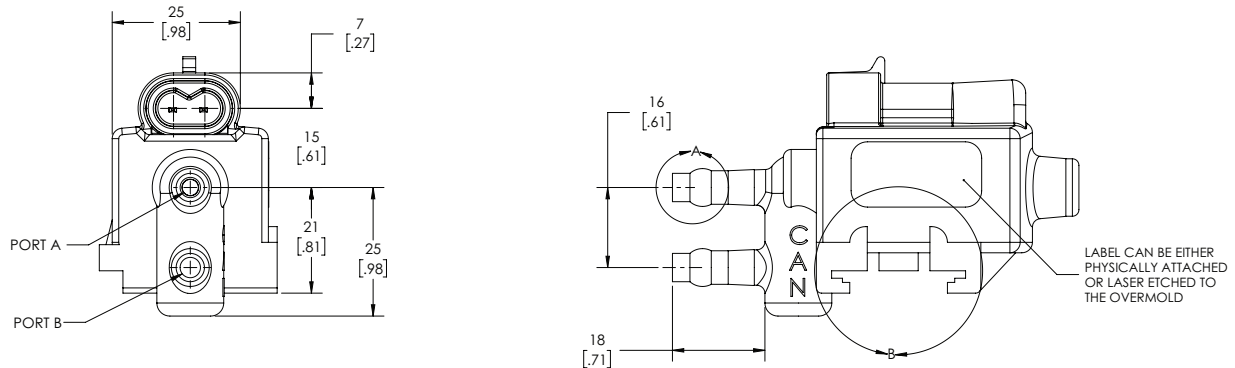

Legal Disclaimer Notice

ALL PRODUCT, PRODUCT SPECIFICATIONS, AND DATA ARE SUBJECT TO CHANGE WITHOUT NOTICE TO IMPROVE RELIABILITY, FUNCTION, DESIGN OR OTHERWISE.

TLX Technologies, LLC makes no warranty, representation or guarantee regarding the suitability of the products for any particular purpose or the continuing production of any product. To the maximum extent permitted by applicable law, TLX Technologies disclaims (i) any and all liability arising out of the application or use of any product, (ii) any and all liability, including without limitation special, consequential or incidental damages, and (iii) any and all implied warranties, including warranties of fitness for particular purpose, non-infringement and merchantability.

Statements regarding the suitability of products for certain types of applications are based on TLX Technologies' knowledge of typical requirements that are often placed on TLX Technologies' products in generic applications. Such statements are not binding statements about the suitability of products for a particular application. It is the customer's responsibility to validate that a particular product with the properties described in the product specification is suitable for use in a particular application. Parameters provided in data sheets and/or specifications may vary in different applications, and performance may vary over time. All operating parameters, including typical parameters, must be validated for each customer application by the customer's technical experts. Product specifications do not expand or otherwise modify TLX Technologies' terms and conditions of purchase, including but not limited to the warranty expressed therein.

No license, express or implied, by estoppel or otherwise, to any intellectual property rights is granted by this document or by any conduct of TLX Technologies. Product names and markings noted herein may be trademarks of their respective owners.